

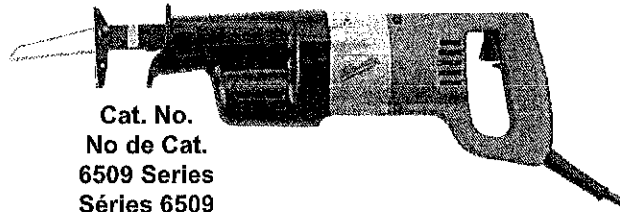

OPERATOR'S MANUAL  
MANUEL de L'UTILISATEUR  
MANUAL del OPERADOR

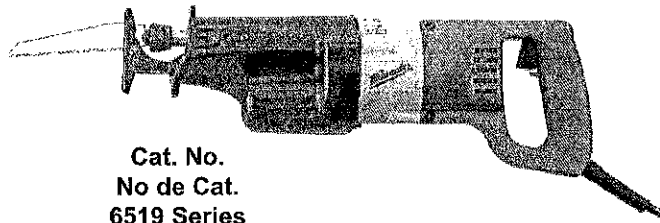

Cat. No.  
No de Cat.  
6509 Series  
Séries 6509  
Serie 6509



Cat. No.  
No de Cat.  
6519 Series  
Séries 6519  
Serie 6519

SAWZALL®  
PASSE-PARTOUT SAWZALL®  
SIERRAS SABLE SAWZALL®

TO REDUCE THE RISK OF INJURY, USER MUST READ OPERATOR'S MANUAL.  
AFIN DE RÉDUIRE LE RISQUE DE BLESSURES, L'UTILISATEUR DOIT LIRE LE MANUEL DE L'UTILISATEUR.  
PARA REDUCIR EL RIESGO DE LESIONES, EL USUARIO DEBE LEER EL MANUAL DEL OPERADOR.

## GENERAL POWER TOOL SAFETY WARNINGS

**WARNING READ ALL SAFETY WARNINGS AND INSTRUCTIONS.**  
 Failure to follow the warnings and instructions may result in electric shock, fire and/or serious injury.  
**Save all warnings and instructions for future reference**  
 The term "power tool" in the warnings refers to your mains-operated (corded) power tool or battery-operated (cordless) power tool.

### WORK AREA SAFETY

- Keep work area clean and well lit. Cluttered or dark areas invite accidents.
- Do not operate power tools in explosive atmospheres, such as in the presence of flammable liquids, gases or dust. Power tools create sparks which may ignite the dust or fumes.
- Keep children and bystanders away while operating a power tool. Distractions can cause you to lose control.

### ELECTRICAL SAFETY

- Power tool plugs must match the outlet. Never modify the plug in any way. Do not use any adapter plugs with earthed (grounded) power tools. Unmodified plugs and matching outlets will reduce the risk of electric shock.
- Avoid contact with earthed or grounded surfaces such as pipes, radiators, ranges and refrigerators. There is an increased risk of electric shock if your body is earthed or grounded.
- Do not expose power tools to rain or wet conditions. Water entering a power tool will increase the risk of electric shock.
- Do not abuse the cord. Never use the cord for carrying, pulling or unplugging the power tool. Keep cord away from heat, oil, sharp edges or moving parts. Damaged or entangled cords increase the risk of electric shock.
- When operating a power tool outdoors, use an extension cord suitable for outdoor use. Use of a cord suitable for outdoor use reduces the risk of electric shock.
- If operating a power tool in a damp location is unavoidable, use a residual current device (RCD) protected supply. Use of an RCD reduces the risk of electric shock.

### PERSONAL SAFETY

- Stay alert, watch what you are doing and use common sense when operating a power tool. Do not use a power tool while you are tired or under the influence of drugs, alcohol or medication. A moment of inattention while operating power tools may result in serious personal injury.

- Use personal protective equipment. Always wear eye protection. Protective equipment such as dust mask, non-skid safety shoes, hard hat, or hearing protection used for appropriate conditions will reduce personal injuries.
- Prevent unintentional starting. Ensure the switch is in the off-position before connecting to power source and/or battery pack, picking up or carrying the tool. Carrying power tools with your finger on the switch or energising power tools that have the switch on invites accidents.
- Remove any adjusting key or wrench before turning the power tool on. A wrench or a key left attached to a rotating part of the power tool may result in personal injury.
- Do not overreach. Keep proper footing and balance at all times. This enables better control of the power tool in unexpected situations.
- Dress properly. Do not wear loose clothing or jewellery. Keep your hair, clothing and gloves away from moving parts. Loose clothes, jewellery or long hair can be caught in moving parts.
- If devices are provided for the connection of dust extraction and collection facilities, ensure these are connected and properly used. Use of dust collection can reduce dust-related hazards.

### POWER TOOL USE AND CARE

- Do not force the power tool. Use the correct power tool for your application. The correct power tool will do the job better and safer at the rate for which it was designed.
- Do not use the power tool if the switch does not turn it on and off. Any power tool that cannot be controlled with the switch is dangerous and must be repaired.
- Disconnect the plug from the power source and/or the battery pack from the power tool before making any adjustments, changing accessories, or storing power tools. Such preventive safety measures reduce the risk of starting the power tool accidentally.
- Store idle power tools out of the reach of children and do not allow persons unfamiliar with the power tool or these instructions to operate the power tool. Power tools are dangerous in the hands of untrained users.

- Maintain power tools. Check for misalignment or binding of moving parts, breakage of parts and any other condition that may affect the power tool's operation. If damaged, have the power tool repaired before use. Many accidents are caused by poorly maintained power tools.
- Keep cutting tools sharp and clean. Properly maintained cutting tools with sharp cutting edges are less likely to bind and are easier to control.
- Use the power tool, accessories and tool bits etc., in accordance with these instructions, taking into account the working conditions and the work to be performed. Use of the power tool for operations different from those intended could result in a hazardous situation.

### SERVICE

- Have your power tool serviced by a qualified repair person using only identical replacement parts. This will ensure that the safety of the power tool is maintained.

### SPECIFIC SAFETY RULES

- Hold power tools by insulated gripping surfaces when performing an operation where the cutting tool may contact hidden wiring or its own cord. Contact with a "live" wire will make exposed metal parts of the tool "live" and shock the operator.
- Use clamps or another practical way to secure and support the workpiece to a stable platform. Holding the work by hand or against your

body leaves it unstable and may lead to loss of control.

- Keep hands away from all cutting edges and moving parts.
- Maintain labels and nameplates. These carry important information. If unreadable or missing, contact a MILWAUKEE service facility for a free replacement.
- WARNING Some dust created by power sanding, sawing, grinding, drilling, and other construction activities contains chemicals known to cause cancer, birth defects or other reproductive harm. Some examples of these chemicals are:
  - lead from lead-based paint
  - crystalline silica from bricks and cement and other masonry products, and
  - arsenic and chromium from chemically-treated lumber.

Your risk from these exposures varies, depending on how often you do this type of work. To reduce your exposure to these chemicals: work in a well ventilated area, and work with approved safety equipment, such as those dust masks that are specifically designed to filter out microscopic particles.

### Specifications

Cat. No.	Volts AC	Amps	No Load RPM	Length of Stroke
6509 Series	120	11	0 - 2 800	3/4"
6519 Series	120	11	0 - 2 800	1-1/8"

### FUNCTIONAL DESCRIPTION

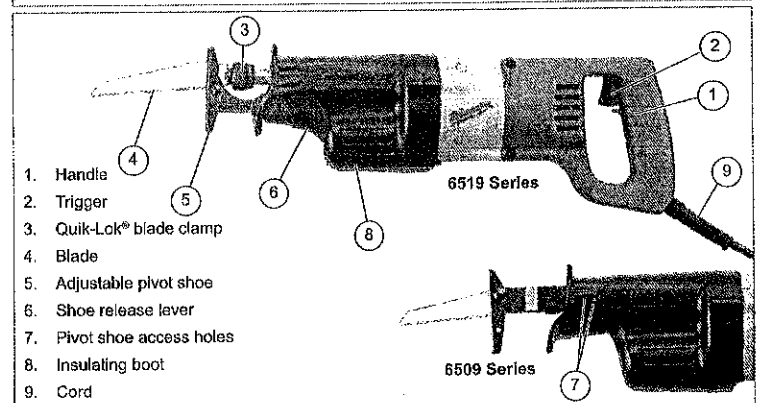

## GROUNDING

**⚠ WARNING** Improperly connecting the grounding wire can result in the risk of electric shock. Check with a qualified electrician if you are in doubt as to whether the outlet is properly grounded. Do not modify the plug provided with the tool. Never remove the grounding prong from the plug. Do not use the tool if the cord or plug is damaged. If damaged, have it repaired by a MILWAUKEE service facility before use. If the plug will not fit the outlet, have a proper outlet installed by a qualified electrician.

### Grounded Tools: Tools with Three Prong Plugs

Tools marked "Grounding Required" have a three wire cord and three prong grounding plug. The plug must be connected to a properly grounded outlet (See Figure A). If the tool should electrically malfunction or break down, grounding provides a low resistance path to carry electricity away from the user, reducing the risk of electric shock.

The grounding prong in the plug is connected through the green wire inside the cord to the grounding system in the tool. The green wire in the cord is the only wire connected to the tool's grounding system and must never be attached to an electrically "live" terminal.

Your tool must be plugged into an appropriate outlet, properly installed and grounded in accordance with all codes and ordinances. The plug and outlet should look like those in Figure A.

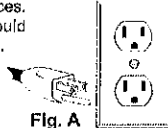

Fig. A

### Double Insulated Tools: Tools with Two Prong Plugs

Tools marked "Double Insulated" do not require grounding. They have a special double insulation system which satisfies OSHA requirements and complies with the applicable standards of Underwriters Laboratories, Inc., the Canadian Standard Association and the National Electrical Code. Double insulated tools may be used in either of the 120 volt outlets shown in Figures B and C.

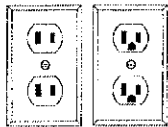

Fig. B

Fig. C

## EXTENSION CORDS

Grounded tools require a three wire extension cord. Double insulated tools can use either a two or three wire extension cord. As the distance from the supply outlet increases, you must use a heavier gauge extension cord. Using extension cords with inadequately sized wire causes a serious drop in voltage, resulting in loss of power and possible tool damage. Refer to the table shown to determine the required minimum wire size.

The smaller the gauge number of the wire, the greater the capacity of the cord. For example, a 14 gauge cord can carry a higher current than a 16 gauge cord. When using more than one extension cord to make up the total length, be sure each cord contains at least the minimum wire size required. If you are using one extension cord for more than one tool, add the nameplate amperes and use the sum to determine the required minimum wire size.

### Guidelines for Using Extension Cords

- If you are using an extension cord outdoors, be sure it is marked with the suffix "W-A" ("W" in Canada) to indicate that it is acceptable for outdoor use.
- Be sure your extension cord is properly wired and in good electrical condition. Always replace a damaged extension cord or have it repaired by a qualified person before using it.
- Protect your extension cords from sharp objects, excessive heat and damp or wet areas.

### Recommended Minimum Wire Gauge for Extension Cords\*

Nameplate Amperes	Extension Cord Length				
	25'	50'	75'	100'	150'
0 - 2.0	18	18	18	18	16
2.1 - 3.4	18	18	18	18	14
3.5 - 5.0	18	18	16	14	12
5.1 - 7.0	18	16	14	12	12
7.1 - 12.0	16	14	12	10	
12.1 - 16.0	14	12	10		
16.1 - 20.0	12	10			

\* Based on limiting the line voltage drop to five volts at 150% of the rated amperes.

**READ AND SAVE ALL  
INSTRUCTIONS FOR  
FUTURE USE.**

## Symbology

	Double Insulated	$n_0 XXXX \text{ min.}^{-1}$	No Load Strokes per Minute (SPM)
$V \sim$	Volts Alternating Current	$c \text{ (U) US}$	Underwriters Laboratories, Inc., United States and Canada
A	Amps		

## ASSEMBLY

**⚠ WARNING** To reduce the risk of injury, always unplug tool before attaching or removing accessories or making adjustments. Use only specifically recommended accessories. Others may be hazardous.

### Selecting a Blade

Use MILWAUKEE Sawzall® Blades for best performance. When selecting a blade, choose the right type and length.

Many types of blades are available for a variety of applications: cutting metal, wood, nail-embedded wood, scroll cutting, roughing-in, and contours.

Many lengths are also available. Choose a length long enough to extend beyond the shoe and your work throughout the stroke. For best performance and longest life, see "Accessories" to select the best blade for the job.

### Installing and Removing Blades

#### Quik-Lok® Blade Clamp

- Unplug the tool.
- Be sure the spindle and blade clamp areas are clean. Metal chips and sawdust may prevent the Quik-Lok® Blade Clamp from clamping securely (see "Maintenance").
- To install a blade, twist the collar in the direction of the arrow while inserting the blade into the clamp until the tang butts against the collar.

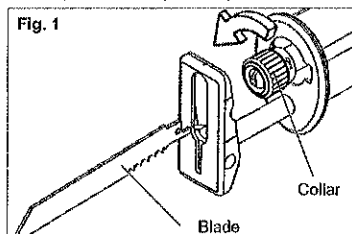

Fig. 1

Depending on the job, the blade may be inserted with the teeth facing upward or downward.

- Release the collar and the spring loaded mechanism will clamp the blade firmly in place.
- Twist the collar in the opposite direction of the arrow to ensure that the blade is locked into the clamp.
- Tug on blade to make sure it is securely locked in place.
- To remove a blade, twist the collar in the direction of the arrow while pulling on the blade. Be careful when handling hot blades.

### Removing Broken Blades from the Quik-Lok® Blade Clamp

- Unplug the tool.
- Broken blades can be removed by the following methods.
  - Point the tool downward, twist the collar, and shake the tool up and down (DO NOT turn on the tool while your fingers are holding the blade clamp open). The shank of the broken blade should drop out of the clamp.
  - If shaking the tool doesn't work... In most cases, a corner of the broken blade will extend beyond the blade clamp. Twist the collar and pull the broken blade out of the clamp by this corner.
  - If the broken stub doesn't extend far enough to be grabbed by its corner, use a thin blade with small teeth (such as a metal cutting blade) to hook the blade that is jammed in the clamp while twisting the collar and pull it out.

### Blade Clamp (Accessory 49-22-5016)

1. Unplug the tool before changing blades.
2. Be sure the spindle and blade clamp area are clean. Metal chips and sawdust may prevent the blade clamp screw from clamping securely.
3. To install a blade, loosen the blade clamp screw, turning it counterclockwise. Insert the blade until the tang butts against the spindle.

**NOTE:** The blade must be inserted all the way into the spindle so that the tang on the blade seats firmly in the blade clamp.

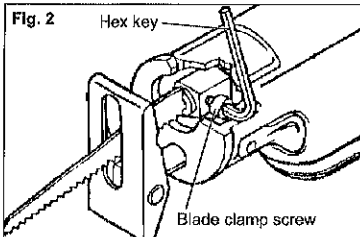

Depending on the job, the blade may be inserted with the teeth facing upward or downward.

4. Insert the hex key into the blade clamp screw, turn it counterclockwise. Tighten securely.
5. To remove a blade, insert hex key into the blade clamp screw and turn it counterclockwise 1 full turn. Then slide the blade out of the spindle. Be careful when handling hot blades.

### Adjustable Pivot Shoe

The shoe can be adjusted forward or backward to take advantage of the unused portion of the blade or for special jobs requiring low blade clearance.

**WARNING** Do not operate Sawzall without a shoe. Striking the spindle against the work may damage the reciprocating mechanism.

#### 6509 Series

1. To adjust the shoe, place hex wrench through access holes in insulating boot and loosen four (4) screws.
2. Move shoe to desired position.
3. Tighten screws.
4. After adjusting the shoe, slowly pull the trigger to be sure the blade always extends beyond the shoe and your work throughout the stroke.

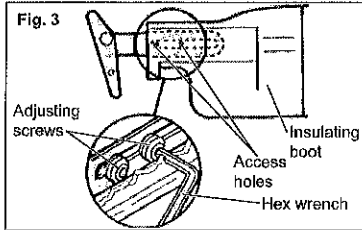

#### 6519 Series

1. To adjust the shoe, pull out the shoe release lever 1/4 turn.
2. Slide the shoe forward or backward to the desired position.
3. To lock the shoe in position, push in the shoe release lever.
4. After adjusting the shoe, slowly pull the trigger to be sure the blade always extends beyond the shoe and your work throughout the stroke.

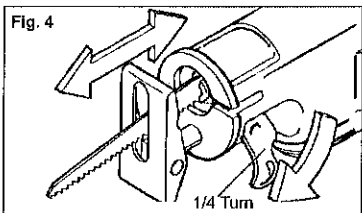

6

**WARNING** To reduce the risk of injury, be sure the blade always extends beyond the shoe and work throughout the stroke. Blades may shatter if they impact the work or shoe (Fig. 5).

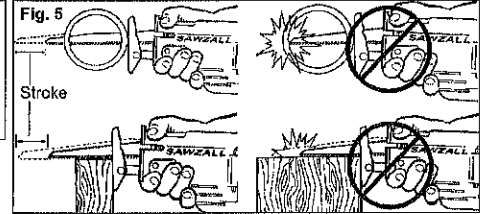

### OPERATION

**WARNING** To reduce the risk of injury, always unplug tool before attaching or removing accessories or making adjustments. Use only specifically recommended accessories. Others may be hazardous.

**WARNING** To reduce the risk of injury, wear safety goggles or glasses with side shields.

#### Impact Protection System

Select models are equipped with a unique patented gearing system that provides efficient power transmission and extended life in the most difficult cutting applications. This durable system will absorb impacts, blade lock ups, and motor stalls. These models can be used for extreme cutting applications such as large diameter pipe, thick metal, pallets, and heavy demolition and renovation work as well as for general purpose cutting.

#### Starting, Stopping and Controlling Speed

To start the tool, grasp the handle firmly and pull the trigger.

To stop the tool, release the trigger. Allow the tool to come to a complete stop before removing the blade from a partial cut or laying the tool down.

#### Trigger Speed Control Switch

MILWAUKEE Sawzalls® are equipped with a trigger speed control switch. It may be operated at any speed from zero strokes per minute to full speed. Always start tool before blade contacts the workpiece. To vary the speed, simply increase or decrease the pressure on the trigger. The further the trigger is pulled, the greater the speed. To stop the tool, release the trigger and allow the tool to stop completely before removing from a partial cut or before laying the tool down.

#### General Cutting

For straight or contour cutting from an edge, line the blade up with your cutting line. Before the blade contacts the workpiece, grasp the handle firmly and pull the trigger. Then guide the tool along your cutting line. Always hold the shoe flat against the workpiece to avoid excessive vibration.

#### Cutting Metals

Begin cutting at a slow speed, gradually increasing speed as you cut. When cutting into metals or hard materials that can not be cut from an edge, drill a starting hole larger than the widest part of the blade. Extend blade life by using a solid blade cutting lubricant such as MILWAUKEE Band Saw Blade Lubricant Cat. No. 49-08-4206.

#### Plunge Cutting

Your MILWAUKEE Sawzall® is ideal for plunge cutting directly into surfaces that can not be cut from an edge, such as walls or floors. Plunge cutting may be done two ways depending on how the blade is inserted. Column A shows how to plunge cut with the teeth of the blade facing down. Column B shows how to plunge cut with the teeth of the blade facing up. Do not plunge cut into metal surfaces (see "Cutting Metals").

**WARNING** To reduce the risk of explosion, electric shock and property damage, always check the work area for hidden gas pipes, electrical wires or water pipes when making blind or plunge cuts.

7

1. Insert the blade into the tool.

If you inserted the blade with the teeth facing downward, hold the tool as shown in Column A, resting the edge of the shoe on the workpiece.

If you inserted the blade with the teeth facing upward, hold the tool as shown in Column B, resting the edge of the shoe on the workpiece as shown.

2. With the blade just above the workpiece, pull the trigger. Using the edge of the shoe as a pivot, lower the blade into the workpiece as shown.

3. As the blade starts cutting, raise the handle of the tool slowly until the shoe rests firmly on the workpiece. Then guide the tool along your cutting line to acquire the desired cut.

**NOTE:** To make plunge cutting easier, use a heavy gauge blade and install the blade with the teeth facing upward as shown in Column B.

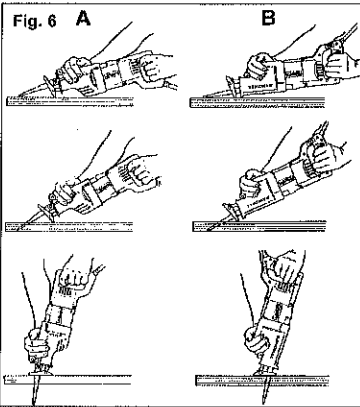

**ACCESSORIES**

**WARNING** To reduce the risk of injury, always unplug the tool before attaching or removing accessories. Use only specifically recommended accessories. Others may be hazardous.

For a complete listing of accessories refer to your MILWAUKEE Electric Tool catalog or go on-line to [www.milwaukeeool.com](http://www.milwaukeeool.com). To obtain a catalog, contact your local distributor or a service center.

**MAINTENANCE**

**WARNING** To reduce the risk of injury, always unplug your tool before performing any maintenance. Never disassemble the tool or try to do any rewiring on the tool's electrical system. Contact a MILWAUKEE service facility for ALL repairs.

**Maintaining Tools**  
Keep your tool in good repair by adopting a regular maintenance program. Before use, examine the general condition of your tool. Inspect guards, switches, tool cord set and extension cord for damage. Check for loose screws, misalignment, binding of moving parts, improper mounting, broken parts and any other condition that may affect its safe operation. If abnormal noise or vibration occurs, turn the tool off immediately and have the problem corrected before further use. Do not use a damaged tool. Tag damaged tools "DO NOT USE" until repaired (see "Repairs").

Under normal conditions, relubrication is not necessary until the motor brushes need to be replaced. After six months to one year, depending on use, return your tool to the nearest MILWAUKEE service facility for the following:

- Lubrication
- Brush inspection and replacement
- Mechanical inspection and cleaning (gears, spindles, bearings, housing, etc.)
- Electrical inspection (switch, cord, armature, etc.)
- Testing to assure proper mechanical and electrical operation

**WARNING** To reduce the risk of injury, electric shock and damage to the tool, never immerse your tool in liquid or allow a liquid to flow inside the tool.

**Cleaning**  
Clean dust and debris from vents. Keep the tool handles clean, dry and free of oil or grease. Use only mild soap and a damp cloth to clean your tool since certain cleaning agents and solvents are harmful to plastics and other insulated parts. Some of these include: gasoline, turpentine, lacquer thinner, paint thinner, chlorinated cleaning solvents, ammonia and household detergents containing ammonia. Never use flammable or combustible solvents around tools.

**Repairs**  
If your tool is damaged, return the entire tool to the nearest service center.

**FIVE YEAR TOOL LIMITED WARRANTY**

Every MILWAUKEE electric power tool (including battery charger) is warranted to the original purchaser only to be free from defects in material and workmanship. Subject to certain exceptions, MILWAUKEE will repair or replace any part on a electric power tool which, after examination, is determined by MILWAUKEE to be defective in material or workmanship for a period of five (5) years\* after the date of purchase. Return the electric power tool and a copy of proof of purchase to a MILWAUKEE factory Service/Sales Support Branch location or MILWAUKEE Authorized Service Station, freight prepaid and insured, are requested for this warranty to be effective. This warranty does not apply to damage that MILWAUKEE determines to be from repairs made or attempted by anyone other than MILWAUKEE authorized personnel, misuse, alterations, abuse, normal wear and tear, lack of maintenance, or accidents.

\* The warranty period for Hoists (lever, hand chain, & electric chain hoists), all Ni-CD battery packs, Work Lights (cordless flashlights), Job Site Radios, and Trade Titan™ Industrial Work Carts is one (1) year from the date of purchase. \*The warranty period for Li-Ion battery packs that do not contain V™-technology – 4.0 volts through 18.0 volts - is two (2) years from the date of purchase.

\*There is a separate warranty for V™-technology Li-Ion Battery Packs V™18 volts and above that accompany V™-technology cordless power tools:

\*Every MILWAUKEE V™-technology Li-Ion Battery Pack 18 volts or above is covered by an initial 1000 Charges/2 Years free replacement warranty. This means that for the earlier of the first 1000 charges or two (2) years from the date of purchase/first charge, a replacement battery will be provided to the customer for any defective battery free of charge. Thereafter, customers will also receive an additional warranty on a pro rata basis up to the earlier of the first 2000 charges or five (5) Years from the date of purchase/first charge. This means that every customer gets an additional 1000 charges or three (3) years of pro rata warranty on the V™-technology Li-Ion Battery Pack 18 volts or above depending upon the amount of use. During this additional warranty period, the customer pays for only the useable service received over and above the first 1000 Charges/2 years, based on the date of first charge and number of charges found on the battery pack via Milwaukee's V™-technology Service Reader.

Warranty Registration is not necessary to obtain the applicable warranty on a MILWAUKEE product. The manufacturing date of the product will be used to determine the warranty period if no proof of purchase is provided at the time warranty service is requested.

ACCEPTANCE OF THE EXCLUSIVE REPAIR AND REPLACEMENT REMEDIES DESCRIBED HEREIN IS A CONDITION OF THE CONTRACT FOR THE PURCHASE OF EVERY MILWAUKEE PRODUCT. IF YOU DO NOT AGREE TO THIS CONDITION, YOU SHOULD NOT PURCHASE THE PRODUCT. IN NO EVENT SHALL MILWAUKEE BE LIABLE FOR ANY INCIDENTAL, SPECIAL, CONSEQUENTIAL OR PUNITIVE DAMAGES, OR FOR ANY COSTS, ATTORNEY FEES, EXPENSES, LOSSES OR DELAYS ALLEGED TO BE AS A CONSEQUENCE OF ANY DAMAGE TO, FAILURE OF, OR DEFECT IN ANY PRODUCT INCLUDING, BUT NOT LIMITED TO, ANY CLAIMS FOR LOSS OF PROFITS. THIS WARRANTY IS EXCLUSIVE AND IN LIEU OF ALL OTHER WARRANTIES OR CONDITIONS, WRITTEN OR ORAL, EXPRESSED OR IMPLIED. WITHOUT LIMITING THE GENERALITY OF THE FOREGOING, MILWAUKEE DISCLAIMS ANY IMPLIED WARRANTY OF MERCHANTABILITY OR FITNESS FOR A PARTICULAR USE OR PURPOSE, AND ALL OTHER WARRANTIES.

This warranty applies to product sold in the U.S.A., Canada and Mexico only. Please consult the 'Service Center Search' in the Parts & Service section of MILWAUKEE's web-site [www.milwaukeeool.com](http://www.milwaukeeool.com) or call 1.800.SAWDUST (1.800.729.3878) to locate your nearest service facility for warranty and non-warranty service on a MILWAUKEE electric power tool.