

ULINE

H-1679

H-2331

PALLET TRUCK SCALE**1-800-295-5510**

uline.com

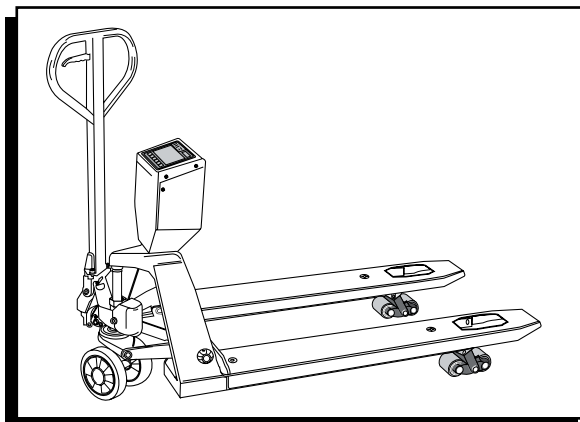

GENERAL INFORMATION

AVOID PLACING THE SCALE IN LOCATIONS THAT MAY AFFECT ACCURACY:

1. Temperature extremes – Do not place in direct sunlight or near air conditioning vents.
2. Keep scale dry – Do not place in high humidity, damp or wet locations.
3. Keep away from air movers like fans or open doors and windows.
4. Keep scale clean.
5. Do not stack items on the scale when not in use.



WARNING! Scale is not waterproof. Avoid direct contact with water, high humidity and condensation. Do not spray or immerse scale in water. Data may become unstable or scale may malfunction. Turn power off and allow scale to dry before reuse.

TABLE OF CONTENTS

SPECIFICATIONS	3
LCD DISPLAY	4
DISPLAY CHARACTERS	5
CONTROLS	6
ASSEMBLY	7-8
SAFETY	9
OPERATION	10-13
BATTERY	14
MAINTENANCE/CALIBRATION	15
PARTS DIAGRAMS	16-19
ERROR CODES	20

SPECIFICATIONS

H-1679 AND H-2331 PALLET TRUCK SCALES

MODEL	H-1679	H-2331
Max. Lifting Weight	5,000 lbs.	
Min. Fork Height	3⅓"	
Max. Fork Height	7½"	
Fork Length	48"	46"
Fork Overall Width	27"	21½"
Individual Fork Width	7"	
Capacity	5,000 lbs.	
Division	1 lb.	
External Resolution	1/5,000	
Internal Resolution	1/600,000	
Stabilization Time	1 Second (Typical)	
Operating Temperature	0~40°C / 32~104°F	
Power Supply	External AC adapter, 12V 500mA, built-in rechargeable battery (lead acid, 6V/10Ah)	
Display	5½ digits LCD digital display with 2 in high digits (white color LED backlight)	
Load Cells	4 Load Cells	

LCD DISPLAY

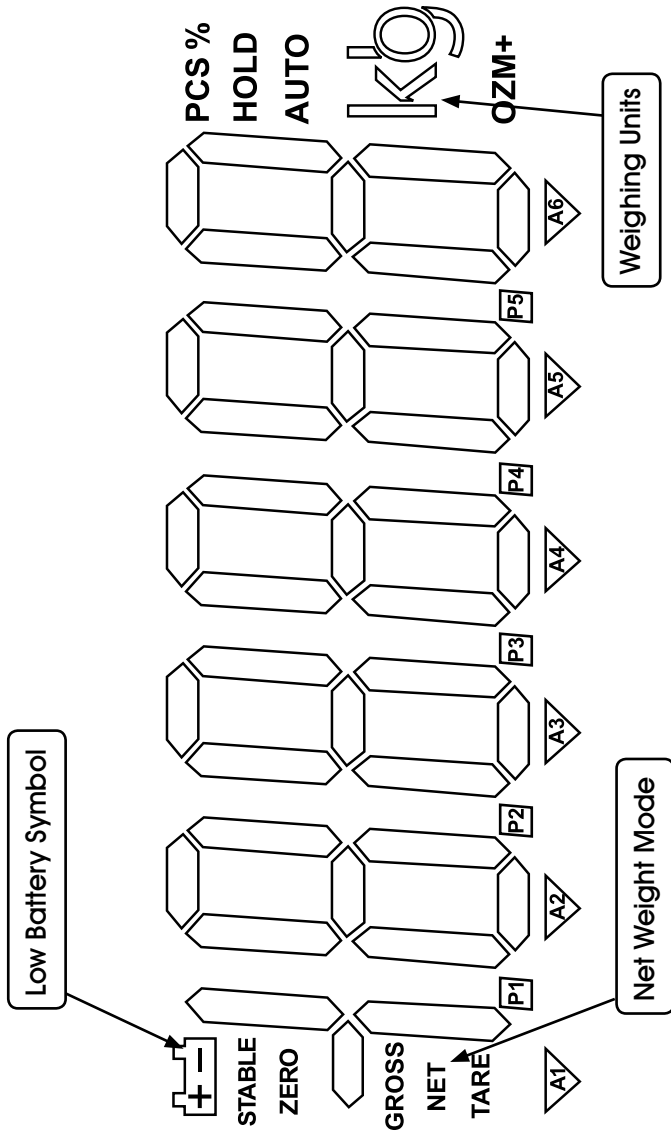

DISPLAY CHARACTERS

CHARACTER	DISPLAY
0	0
1	1
2	2
3	3
4	4
5	5
6	6
7	7
8	8
9	9
A	A
B	b
C	C
D	d
E	E
F	F
G	G
H	H

CHARACTER	DISPLAY
I	i
J	J
K	K
L	L
M	M
N	n
O	O
P	P
Q	Q
R	r
S	S
T	T
U	U
V	v
W	W
X	X
Y	Y
Z	Z

CONTROLS

 primary function

 secondary function

 ON/OFF Key:
Turn the power on or off.

 Zero Key (ZERO):
Zeros display for next weight.

 'ENTER' key to set parameters and other functions.

 Tare Key (TARE):
Deducts the container weight from pieces weight.

 Change number key '^' to set parameters and other functions.

 Pretare Key (PT):
Allows user to manually key in TARE value.

 Spaces right '>' to change different numbers on the display. Also used to set parameters or other functions.

 Accumulate Key (M+):
Adds the value to the accumulation memory. Zero display and press this key to show current total value.

 Spaces left '<' to change different numbers on the display. Also used to set parameters or other functions.

 Gross weight/Net weight (G/N):
Toggle between Gross weight and net weight. Display shift is only available after using tare/pretare functions.

 Acts as a clear key (C) to reset parameters or other functions.

 Unit Key (U):
Selects weighing units: pounds or kilograms.

 Acts as an escape key (ESC) to return the scale to normal operating mode.

ASSEMBLY INSTRUCTIONS

I. CAREFULLY UNPACK ALL ITEMS

1. Remove control panel from packing foam. (See Figure 1)

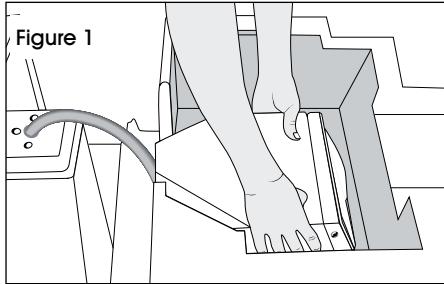

II. ATTACH CONTROL PANEL

1. Feed excess cable into the control panel head. Align three holes in control panel with three holes on pallet truck base. (See Figure 2)

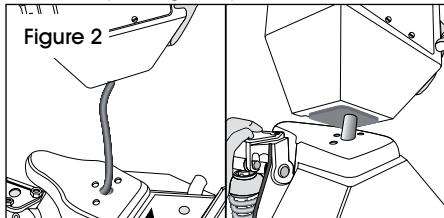

2. Remove the two screws (one on each side) to release the front panel. Carefully open the front panel. (See Figure 3)

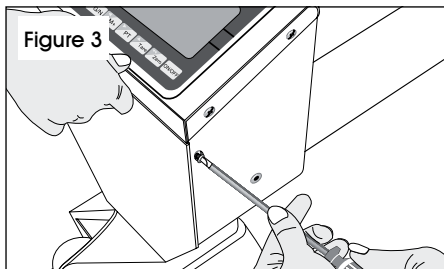

3. Align mounting holes on pallet truck with mounting holes on control panel. (See Figure 4)

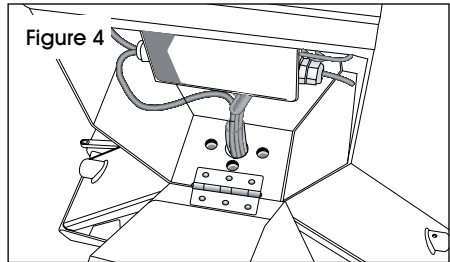

4. Insert and tighten 3 hex screws (H109) with spring washers (H110) through base of control panel with hex wrench provided. (See Figure 5)

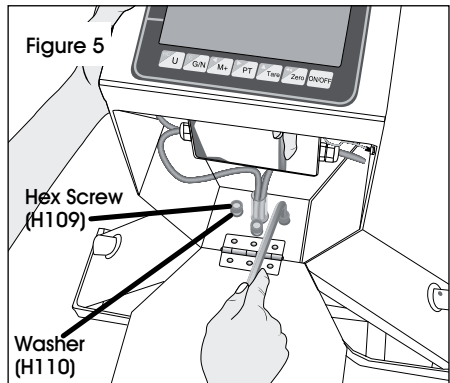

5. Close front panel and secure with 2 screws. (See Figure 6)

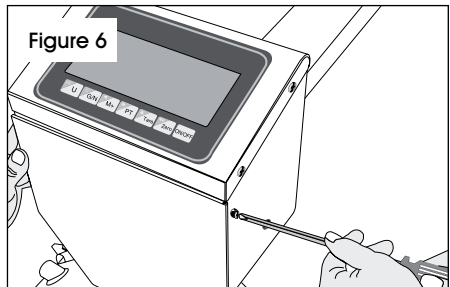

ASSEMBLY INSTRUCTIONS CONTINUED

III. HANDLE INSTALLATION

1. Remove handle from protective wrapping.
2. Loosen set screw (140) on crank link (139H). (See Figure 7)

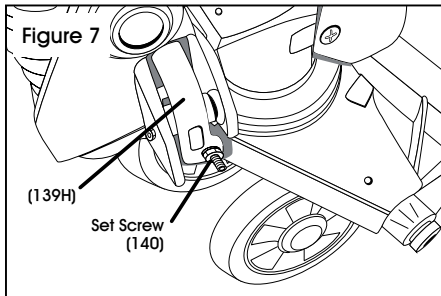

3. Remove 3 hex screws (H109) and 3 spring washers (H110) from bottom of handle.
4. Feed Wire, Chain and Pin (H107) on bottom of handle through center of base (103) and axle (109). (See Figure 8)

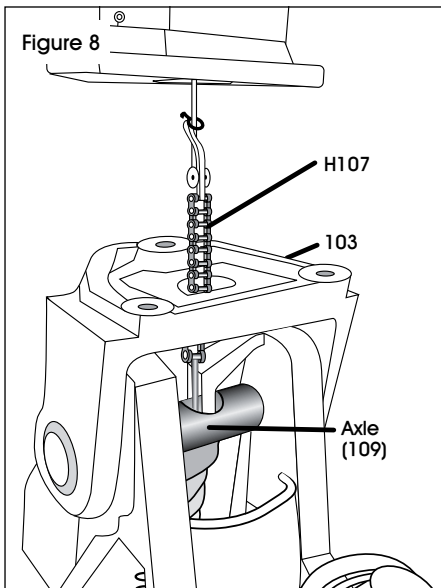

5. Attach handle to base (103) using 3 hex screws (H109) and 3 spring washers (H110) and tighten with Hex Wrench provided. (See Figure 9)

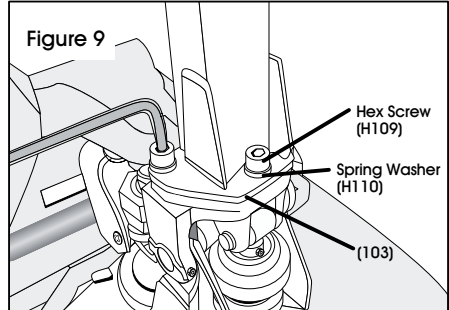

6. While raising crank link (139H), slide pin of rod and chain (H107) into crank link groove. (See Figure 10)

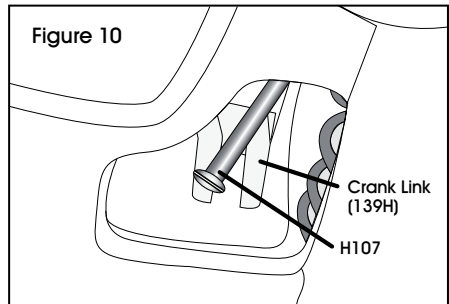

REFERENCE PARTS DIAGRAMS

PAGES 16-19

SAFETY

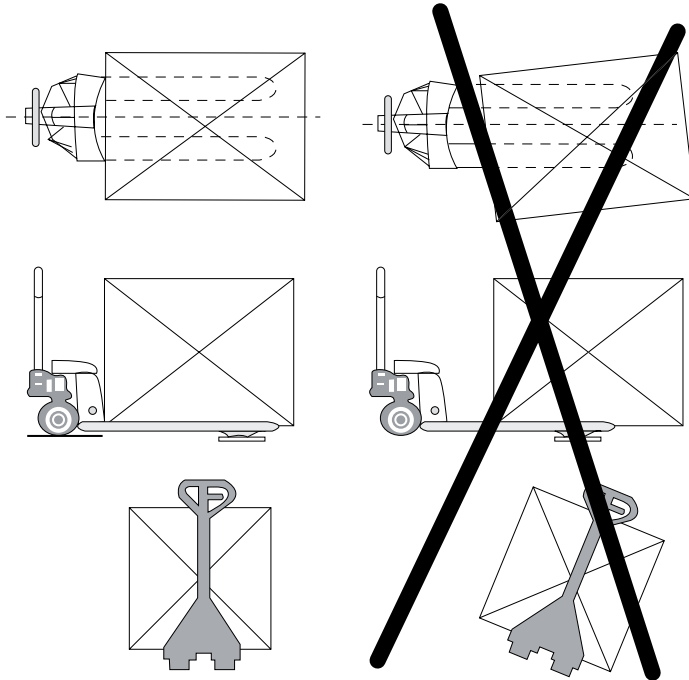

SAFETY NOTE

For safe operation of the truck, please read all warnings and instructions in this guide and on the truck before use.

1. Do not operate the pallet truck unless you are familiar with it and have been trained or authorized to do so.
2. Do not operate the truck unless you have checked its condition. Pay special attention to wheels, handle assembly, forks and controller lever.
3. Do not use the truck on sloping ground.
4. Never place any part of your body in the lifting mechanism or under the forks or load. Do not carry passengers.
5. It is recommended that operator wears gloves and protective shoes while operating the truck.
6. Do not handle unstable or loosely stacked loads.
7. Do not overload the truck.
8. The capacity of the truck assumes an evenly distributed load with the center of the load being at the halfway point of the length of the forks.
9. Make sure that length of the forks matches the length of the pallet.
10. Lower the forks to lowest height when the truck is not being used.

BASIC OPERATIONS

ENSURE FORKS RAISE/LOWER PROPERLY

Control Lever (H106) is located on pallet truck handle (H101) and can be set to 3 positions: LOWER, NEUTRAL and ASCENT.

1. Tighten set screw (140) on crank link (139H) until LOWER position on Control Lever functions properly. (See Handle Installation Step 2).
2. If forks elevate while pumping with Control Lever in NEUTRAL position, turn set screw clockwise until pumping the handle no longer elevates forks and NEUTRAL position functions properly.
3. If forks descend while pumping with Control Lever in NEUTRAL position, turn set screw counter-clockwise until forks no longer descend.
4. If forks do not descend when Control Lever is in LOWER position, turn set screw clockwise until forks lower while in LOWER position.
5. If forks do not elevate while pumping with Control Lever in ASCENT position, turn set screw counter clockwise until the forks elevate while pumping in the ASCENT position. Be sure to re-check NEUTRAL and LOWER positions to ensure proper functioning.

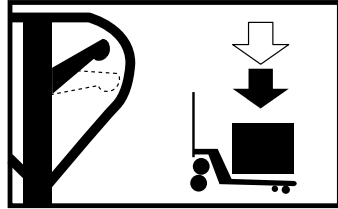

LOWER

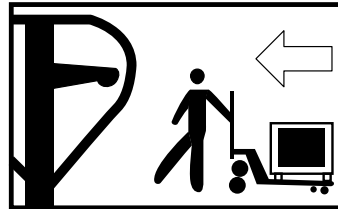

NEUTRAL

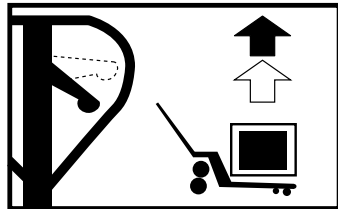

ASCENT

CHARGING THE BATTERY

1. Connect AC adapter into the plug on the side of the control panel. Plug cord into 110/120V AC outlet.
2. Charging time is approximately 15 hours.

BATTERY STATUS (L.E.D. INDICATOR)

- Green - Battery is fully charged.
- Red - Battery is charging.

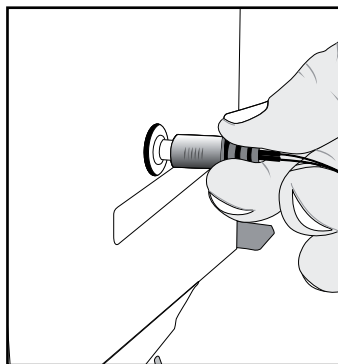

OPERATION

CONTROL LEVER

The control lever (H106) can be set in three positions (see below).

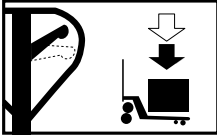

LOWER:
Push lever up to lower
the forks



NEUTRAL:
to move the load

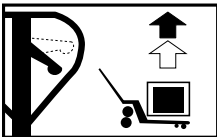

ASCENT:
Push lever down and
pump handle to raise
the forks.

ZEROING THE DISPLAY

You can press the ZERO key at any time to zero the scale. This will usually only be necessary when the pallet is empty. When the zero point is obtained the display will show zero.

The scale has an automatic rezeroing function to account for minor drifting or accumulation of material on the pallet. However, you may need to press the ZERO key to rezero the scale if small amounts of weight are shown when the pallet is empty.

TARING

Zero the scale by pressing the ZERO key if necessary. The zero indicator will be on.

Place a container on the pallet, display shows weight.

Press the TARE key to tare the scale. The weight that was displayed is stored as the tare value and that value is subtracted from the display. Zero shows on display.

The "GROSS" indicator will be off and "NET" indicator on. As product is added, only the weight of the product will be shown. The scale could be tared a second time if another type of product was to be added to the first one. Again only the weight that is added after taring will be displayed.

When the container is removed a negative value will be shown. If the scale was tared just before removing the container this value is the gross weight of the container plus all product that was removed. The zero indicator will be on because the pallet is back to the same condition it was when the ZERO key was last pressed. Press TARE key again to escape "NET" mode.

WEIGHING

Put the control lever in the LOWER position and lower the truck to lowest position.

Press the ON/OFF key to turn the scale on. After the indicator counts down, the display will zero. Place the forks under the pallet. While balancing load as evenly as possible, put lever in "Ascent" position and pump handle to raise load. Once stable indicator shows, the accurate weight of the load is displayed. (Total weight of pallet and the goods)

NET/GROSS FUNCTION

This function is only available after TARE function has been used. Pressing the N/G button will toggle between total weight (gross) on skid and weight after TARE function was used (NET).

SELECTING WEIGHING UNITS

Press U key to select desired weighing units (LBS or KG).

OPERATION CONTINUED

ACCUMULATION

 **NOTE:** Before using Accumulation function, remove all weight from forks and zero the scale.

1. Weigh item on scale. Once "stable" indicator shows, press M+ key to store weight in memory.
2. The display will show "AC 01" and then the total in memory for 2 seconds before returning to normal.
3. The M+ indicator is on. Remove the weight, allow the scale to return to zero, and put a second weight on the scale.
4. Press M+ key, the display shows "AC 02" and then the new total.
5. Continue until all weights have been added. The scale can accumulate up to 99 items.

 **NOTE:** Changing weighing units during Accumulation Function will clear memory.

MEMORY RECALL

To view the totals in memory, press the M+ key while display reads zero, and display will show "AC n" ('n' is current accumulation times) and then the total in memory for 2 seconds. The scale then returns to normal.

TO CLEAR MEMORY

To clear the accumulated data in memory, press G/N key when total weight value is displayed.

PRETARE

1. To set press and hold PT key for 3 seconds to display current tare value.
2. To manually key in a tare value, use TARE key to select value and M+/ PT keys to toggle between active digits.
3. After Pretare value has been entered, press ZERO key.
4. Display now shows "Pts 0". Press TARE key to select desired pretare item. (0-9 preset items are available)
5. Once pretare item is selected, press ZERO key to store pretare value in memory.

 **NOTE:** Pretare value is displayed while NET indicator is shown on display.

SELECT PRETARE

1. Press G/N key to ensure scale is in net mode.
2. Press PT key. "Ptl 0" is shown on display. Press TARE key to select desired stored item (0-9). Press ZERO key to display pretare value.

CLEAR PRETAREVALUE

1. Press PT. Display will show "Ptl 0".
2. Use M+/ PT buttons to select desired pretare item (0-9).
3. Press ZERO key to display pretare weight.
4. Press and hold PT for 3 seconds and follow steps in section I to set pretare value to zero.

PARAMETERS

The scale has parameters that can be set by the user.

1. To set parameters, press the ZERO key and TARE key at the same time.
2. The display will show the first function, "F1 unit".
3. Pressing the TARE key will cycle through the other functions.
4. Pressing ZERO key will allow you to set the function.
5. It may be necessary to either use TARE key set a value or using the M+ and PT key to move the active digit and then using the TARE key to increment a digit, followed by the ZERO key to enter the value.
6. Use the "U" key to leave a parameter unchanged.
7. For example when the display shows "F1 unit" press the ZERO key to begin.

The display will show "ON lb". Press the TARE key to set the weighing unit to ON/OFF status.

1. Press ZERO key to enter value, and the scale will show the next weighing unit. Use TARE key to set and ZERO key to enter. When finished press U key to exit.

OPERATION CONTINUED

FUNCTION SETTING TABLE

FUNCTION	SUB-FUNCTION	DESCRIPTION	DEFAULT VALUE
F1 u nt		Sets the displayed weight unit. Select kg/lb.	kg/lb
F2 dat		Scale will show y-n-d or d-n-y at first, this is date format (year-month-date or date-month-year). Then you need set year, month and date.	2000/01/01 00:00
	yy	Set year: The display will show current year or 2000. Enter new year.	
	mmdd	Set date: The display will show current date or 01.01, enter new date, format mm.dd (month/date).	
	hhmm	Set time: The display will show current time or 00.00. Enter new time, format hh.mm (hour/minute).	
F3 off	CLOCK	Set clock off or on. Off: Don't use clock function. On: Clock display after scale is on standby for 5 minutes.	CLK off
	Bk	Set the backlight. On: Always on. Auto: Press a key and weight is more than 20d, backlight comes on automatically. Off: Always off.	Auto
	Off	Set auto power off. 0: Don't use auto power off function. 3: Auto power off after standby 3 minutes. 5: Auto power off after standby 5 minutes. 15: Auto power off after standby 15 minutes. 30: Auto power off after standby 30 minutes.	of 0

BATTERY OPERATION

BATTERY LIFE

The weighing indicator is battery operated. The battery life is approximately 60 hours.

LOW BATTERY INDICATOR

When the battery needs charging the battery symbol on the display turns on. The battery should be charged. The scale will operate for about 30 minutes then automatically switch off to protect the battery.

CHARGING THE BATTERY

Plug in the AC adapter. Scale does not need to be turned on. Battery should be charged for 15 hours for full capacity.

BATTERY CHARGING STATUS

On the left side of display window, an LED indicates battery charging status. When the scale is plugged in the internal battery will charge. Colors in the LED window indicate battery status:

- Green – Battery is fully charged.
- Red – Battery needs recharging.

Over time, the battery may fail to hold a full charge and eventually will need replacing.



WARNING! Never use any damaged charger or battery. Do not short circuit the battery across the + and - terminals. Do not dispose of batteries in a fire or in household waste. Check local regulations for proper disposal.

BATTERY PERFORMANCE

Always use original batteries and AC adapter. Scale is not intended for use with non-original batteries and/or battery chargers.

- AC adapter rating is 12V.
- New batteries or batteries stored for long periods of time may require longer charging times.
- Keep battery at or near room temperature when charging.
- Do not expose batteries to temperatures below 14°F (-10°C) or above 113°F (45°C).
- Fully charge battery before first use.
- Batteries should be charged once every 3 months at minimum.
- As the battery is used it may fail to hold a full charge. If the battery life becomes unacceptable, contact Uline Customer Service at 1-800-295-5510.

MAINTENANCE

DAILY CHECK AND MAINTENANCE

A daily check of the pallet truck can help prevent accidents. Give special attention to the wheels (127), the axles (109), the handle (H101), the forks and control lever (H106). The forks should be unloaded and lowered in the lowest position when the job is completed.

LUBRICATION

Use motor oil or grease to lubricate all moveable parts.

GENERAL MAINTENANCE

1. Please check the oil level every six months. The volume of oil is about 10.1 fl. oz.

2. Use the hydraulic type oil according to temperature scale below.

Temperature	Oil
-5°C ~ +45°C	L-HM68 Hydraulic oil (equivalent to ISO VG68)
-15°C ~ -5°C	L-HM46 Hydraulic oil (equivalent to ISO VG46)

EXPEL AIR FROM THE PUMP UNIT

Air may get into the hydraulics due to transportation or pump disturbances. It can prevent forks from elevating while pumping in ASCENT position. To expel air: Put the control lever (H106) to the LOWER position, then move the handle (H101) up and down several times.

CALIBRATION

ENTER TECHNICAL PARAMETER MODE



NOTE: Must use 10% of capacity to calibrate.

1. Press ZERO and TARE keys at the same time. The display shows "F1 UNIT".
2. Press TARE key until display shows "PROG" and press ZERO key to show "PN" on the display.
3. Press in order M+, U and TARE keys to enter technical parameter setting mode.
4. Press TARE key to select parameter, press Zero key to enter value and U key to exit.
5. It may be necessary to use TARE key to set a value or use M+ and PT keys to move the active digit.

CALIBRATION

1. Enter Technical Parameter Setting mode(see steps 1-3 above) until display shows "P1 rEF".
2. Press the TARE key until display shows "P2 CAL". Press ZERO key to enter and press TARE key until display shows "CAL".

Press ZERO key to enter calibration mode.

3. After entering calibration mode, the display will show "UNLD". Remove all weight from fork, and after stable indicator shows, press the ZERO key.
4. The display shows the calibration weight value. Use the M+, PT and TARE keys to set the weight value.



NOTE: Use M+/PT keys to move active digit, use TARE key to change value. Also you can also press G/N to make value zero.

5. After weight is keyed, press ZERO key to enter. Display will show "LOAD".
6. Add calibration weight onto forks. After STABLE indicator is visible press ZERO key to enter.
7. Display returns to normal once calibration is successful. If an error message is shown, try the calibration steps again; a disturbance may have prevented a successful calibration. If the problem persists, please contact Uline Customer Service.

PARTS DIAGRAM

DIAG 1

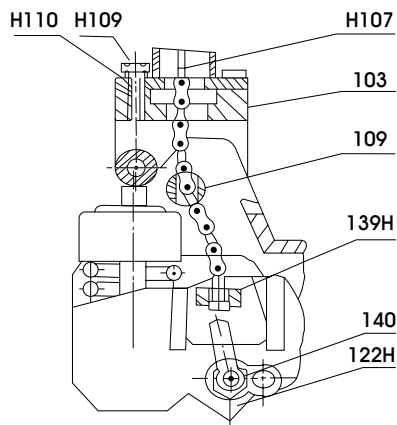

DIAG 2

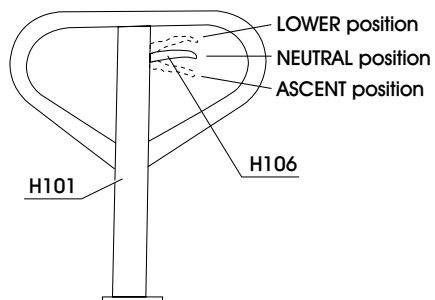

DIAG 3

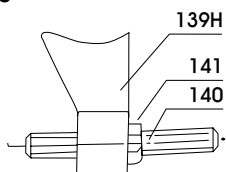

PART NO.	PART NAME	QTY.
H107	Wire, Chain and Pin	1
H109	Hex Screw	6
H110	Spring Washer	6
122H	Pump Housing	6
139H	Crank Link	1
103	Base	1
109	Axle	1
140	Set Screw	1
141	Nut	1
H101	Handle	1
H106	Control Lever	1

PARTS DIAGRAM CONTINUED

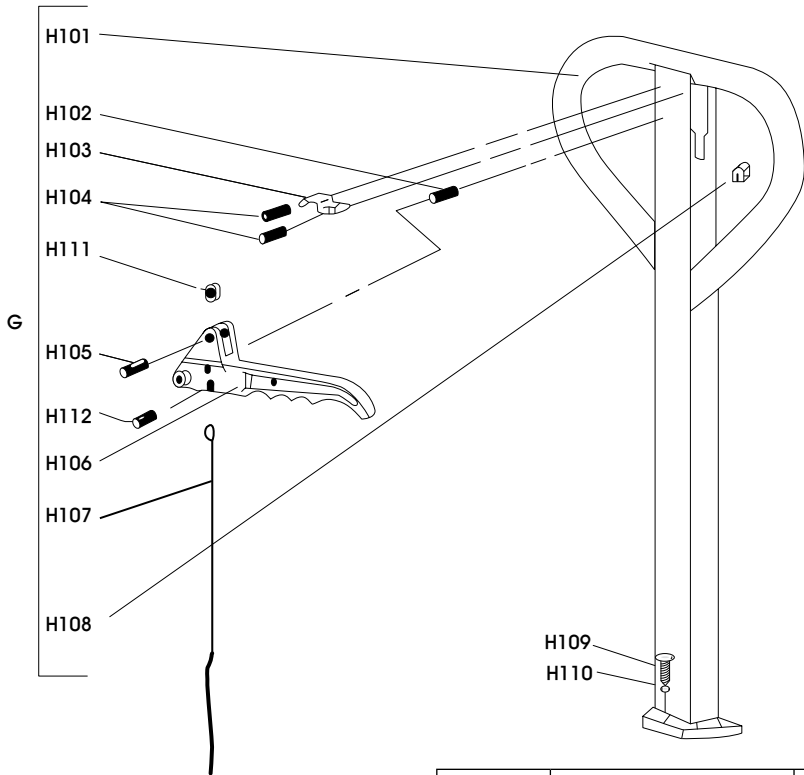

PART NO.	PART NAME	QTY.
H101	Handle	1
H102	Spring Pin	1
H103	Spring Leaf	1
H104	Spring Pin	2
H105	Spring Pin	1
H106	Control Lever	1
H107	Wire, Chain and Pin	1
H108	Rubber Cushion	1
H109	Hex Screw	6
H110	Spring Washer	6
H111	Nylon Roller	1
H112	Spring Pin	1

PARTS DIAGRAM CONTINUED

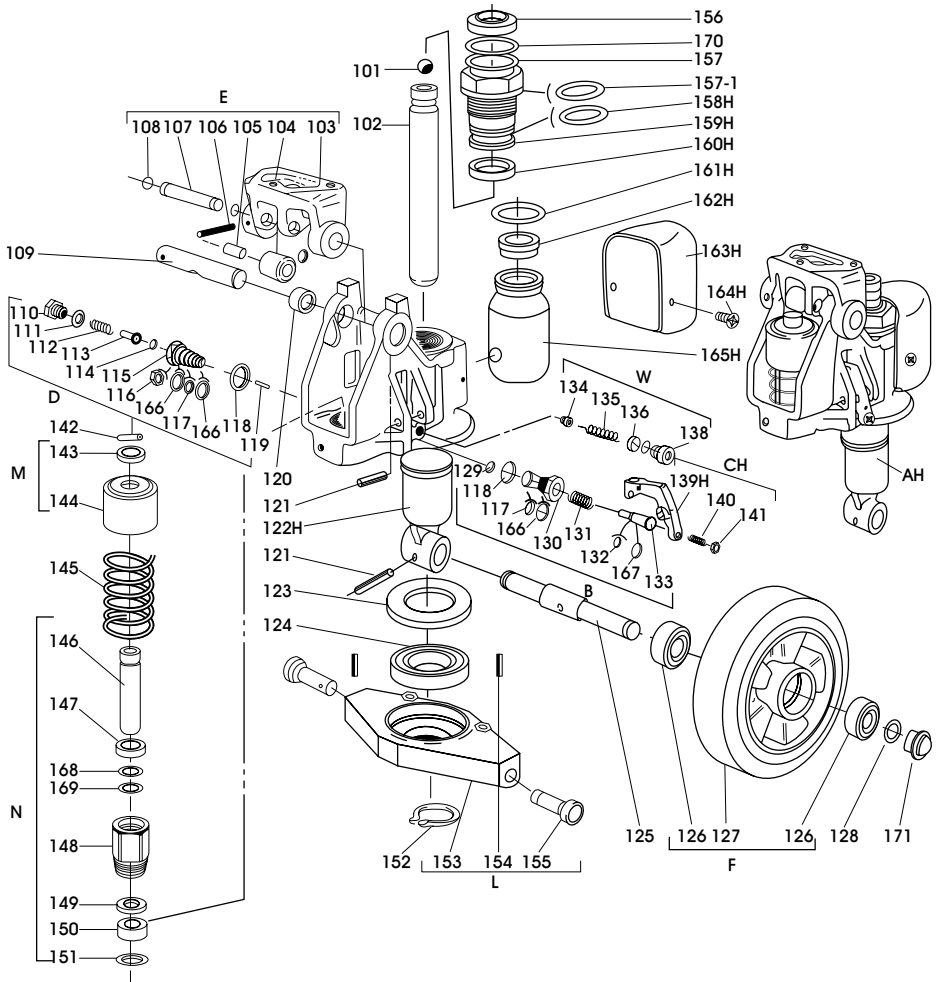

PARTS LIST

PART NO.	PART NAME	QTY.
101	Steel Ball	1
102	Rod	1
103	Base	1
104	Steel Roller	1
105	Bushing	1
106	Pin	1
107	Shaft	2
108	Retaining Ring	1
109	Axle	1
110	Screw	1
111	Washer	1
112	Spring	1
113	Pressure Rod	1
114	Steel Ball	1
115	Pressure Valve Body	1
116	Split Ring	1
117	O-Ring	2
118	Washer	2
119	Steel Needle	1
120	Bushing	2
121	Pin	1
122H	Pump Body	1
123	Dust Cover	1
124	Bearing	1
125	Steering Wheel Axle	1
126	Bearing	4
127	Steering Wheel	2
128	Retaining Ring	2
129	Steel Ball	1
130	Discharge Valve Body	1
131	Spring	1
132	O-Ring	1
133	Discharge Valve Shaft	1
134	Valve Taper Core	1
135	Spring	1
136	Pressure Regulating O-Ring	1

PART NO.	PART NAME	QTY.
138	Screw	1
139H	Crank Link	1
140	Set Screw	1
141	Nut	1
142	Parallel Pin	1
143	Retaining Cover	1
144	Spring Cover	1
145	Spring	1
146	Pump Rod	1
147	Dust Proof Ring	1
148	Pump Cylinder	1
149	Seal Ring	1
150	Nylon Bushing	1
151	Red Copper Washer	1
152	Retaining Ring	1
153	Rhombus Plate	1
154	Pin	1
155	Dowel Pin	2
156	Dust Proof Ring	2
157	O-Ring	1
157-1	O-Ring	1
158H	O-Ring	1
159H	Cylinder	1
160H	Seal Ring	1
161H	O-Ring	1
162H	Filler Plug	1
163H	Reservoir Cover	1
164H	Screw	1
165H	Reservoir	2
166	Retainer	1
167	Retainer	3
168	Retainer	1
169	O-Ring	1
170	Dust Cover	1
171	Bearing Cover	2

ERROR CODES

ERROR CODES	DESCRIPTION	RESOLUTION
-----	Overload	Remove weight from the scale. If the problem persists contact Uline Customer Service.
Err 1	Date Setting Error	Enter date using correct format. Format: yy:mm:dd
Err 2	Time Setting Error	Enter time using correct format. Format: hh:mm:ss
Err 4	Zero Setting Error	The scale was outside the normal zero setting range either when it was turned on or when the ZERO key was pressed. Remove weight from the scale and try again. Use the TARE key to set the display to zero value. If the problem persists contact Uline Customer Service.
Err 6	A/D out of range	The values from the A/D converter are outside the normal range. Remove weight from the scale if overloaded, make sure fork cover plate is attached. Indicates the load cell or the electronics may be faulty. If the problem persists contact Uline Customer Service.